

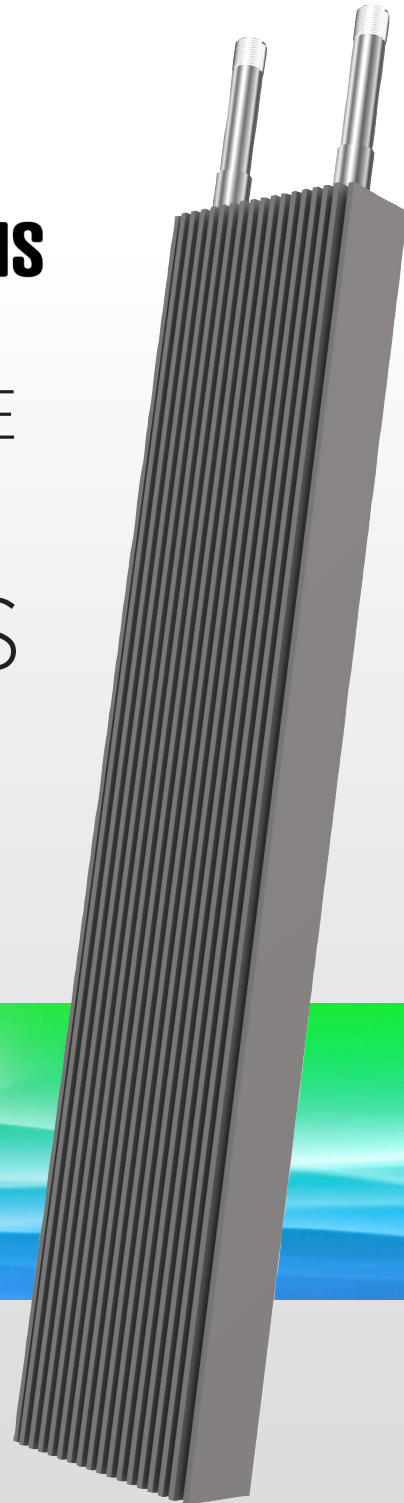

# **ACTIVE CHEMICAL SYSTEMS**

IMPERVIOUS GRAPHITE  
IMMERSION  
PLATE HEATERS





## ACTIVE CHEMICAL SYSTEMS

# IMPERVIOUS GRAPHITE IMMERSION PLATE HEATERS

All IMPREG-TITE® Impervious Graphite Plate Heaters are immune to the effects of thermal shock and are unaffected by the normal action of all standard pickling and plating solutions except chromic acid.

Plate Heaters are supplied with a length of 47 inches without cement joints and can be immersed in solutions of nitric and hydrofluoric acids. With cement joints for standard service, Plate Heaters are supplied with lengths to 94 inches.

IMPREG-TITE® Plate Heaters are designed and manufactured for direct suspension in open tanks with external ribs for added heat transfer. Unlike metal, graphite is not affected by fatigue due to age or pulsating pressure service and will not contaminate either the materials being processed or the pickling solution.

All ACS IMPREG-TITE® Plate Heaters are designed and manufactured to operate at a maximum temperature of 340°F (171°C). Maximum steam pressure is 50 psig and maximum hydrostatic pressure is 75 psig.

Active Chemical Systems has pioneered the use of Teflon® as a surface coating on plate heaters to reduce scale and surface build-up. Reduction of this condition maintains a high level of heat transfer and facilitates cleaning and maintenance. For applications where mechanical impact damage is a factor protective baskets are available, manufactured of structural F.R.P. grating.

The Engineering Department of Active Chemical Systems, Inc. is available for assistance in determining the needs of your application.

**WHEN ORDERING, SPECIFY SERIES, SIZE NUMBER, AND LENGTH.**

## Mark 1 Series

Vertical Position

Horizontal Connection Unions

Series Flow

Size No.	Width (in.)	Center to Center (in.)	Approximate Outside Surface Area (ft <sup>2</sup> ) per Length (ft.)
1	9½	6	4.0
2	19	15½	7.0
3	28½	25	10.0
4	38	34½	14.0

Side mount on tank allows piping installation free of vapors or solution splashes. Teflon® coating available.

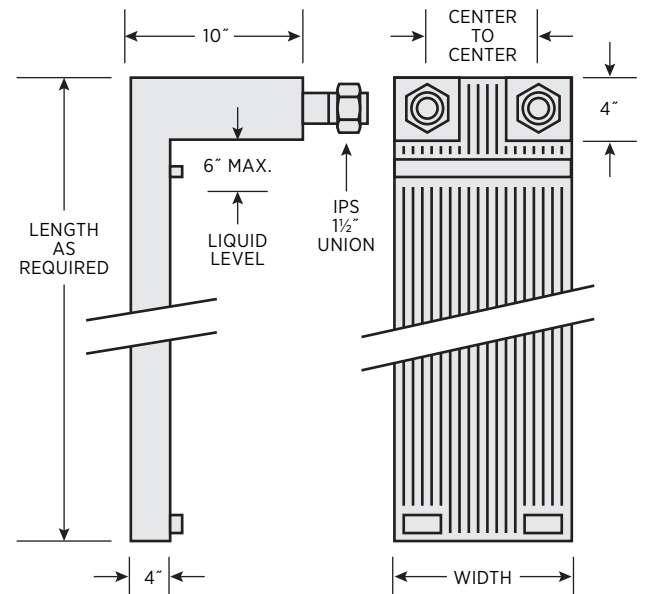

## Mark 2 Series

Vertical Position

Vertical Connection Nipples

Series Flow

Size No.	Width (in.)	Center to Center (in.)	Approximate Outside Surface Area (ft <sup>2</sup> ) per Length (ft.)
1	9	6	3.0
2	18	15	6.0
3	27	24	9.0
4	36	33	12.0

Side mount on tank allows piping installation free of vapors or solution splashes. Teflon® coating available.

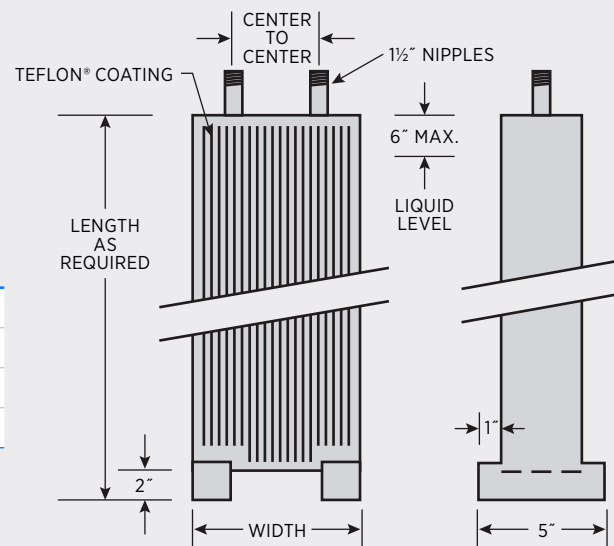

## Mark 3 Series

Vertical Position

Vertical Connection Nipples

Shoulder Mounts

Size No.	Width (in.)	Center to Center (in.)	Approximate Outside Surface Area (ft <sup>2</sup> ) per Length (ft.)
1	9½	6	4.0
2	19	15	7.0
3	28½	24	10.0
4	34½	33	14.0

Side mount on tank allows piping installation free of vapors or solution splashes. Teflon® coating available.

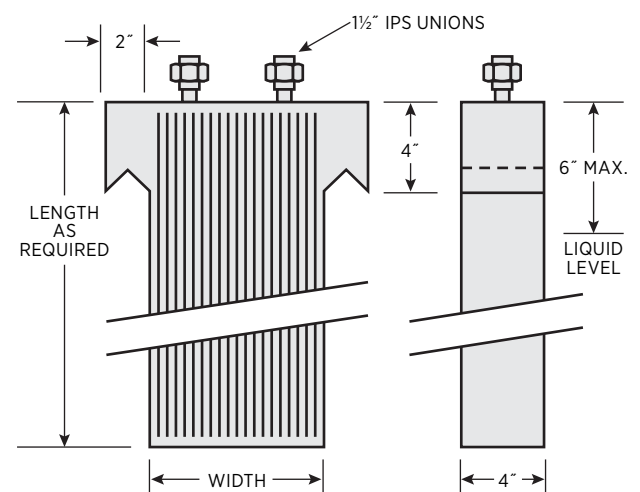

## Mark 5 Series

### Bayonet Heater for Flanged Nozzle or Stuffing Box Mounting

For use in applications where heat transfer requirements are below those dictating plate heater use.

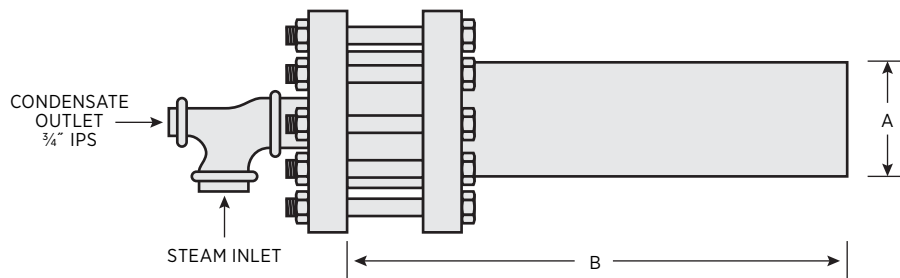

Size No.	A	B	Bolt Cir. Dia. (in.)	Flange Dia. (in.)	Approximate Outside Surface Area per B ft. Length
1½	2	108" max.	5	7	0.5 ft. <sup>2</sup>
2	2¾	108" max.	6	7	0.7 ft. <sup>2</sup>
3	4	108" max.	8½	10½	1.0 ft. <sup>2</sup>

Side mount on tank allows piping installation free of vapors or solution splashes. Teflon® coating available.



## ACTIVE CHEMICAL SYSTEMS

16755 Circle Drive • Chagrin Falls, OH 44023  
(440) 543 8191 • [www.activechemicalsystems.com](http://www.activechemicalsystems.com)